



□ The Electric Range





Italian ingenuity global resources

With more than fifty years' experience in the field of counterbalanced **fork-lift trucks**, CESAB is the Italian centre of excellence within the world's leading group of fork-lift trucks manufacturers.



New quality procedures, with the achievement of **ISO 9001-Vision 2000 certification**, the improvement in the selection of external suppliers, just-in-time logistics, and the modernisation of the product development procedures, have enabled CESAB to supply its customers with **better quality, competitiveness and efficient service.**

Certified ISO 9001 by





Thanks to the activation of industrial, commercial and distribution synergies at the global level, CESAB has moved into new markets, receiving new stimuli to improve, and constantly reaping the rewards of its **high design and production standards**, with a historic orientation towards complete customer satisfaction.



Production flexibility

continuous improvement

Today, the opening out of the world's markets means the logistics function must acquire increasingly flexible, productive and user-friendly handling systems.

CESAB responds to these needs with one of the most high-tech **electric forklift truck ranges** on the market.



A wide range of opportunities

Featuring **unmistakable design**, CESAB electric fork-lift trucks are available with **lifting capacities from 0.8 to 8.5 t** and are especially suitable in applications where, to protect the quality of the working environment, quiet operation and absence of emissions is required.

Thanks to their outstanding **versatility**, they can fulfil a vast range of applications: from handling pallets and various loads in tight spaces to the lifting and transportation of heavy loads in the timber or paper industries.

Thanks to their leading-edge technology, these trucks are **agile and productive**, with economical operating costs, and for customers they are an **immediately profitable investment** that maintains its value over time.

lifting capacity
(tonnes)

from 0,8 to 1,2

from 1,2 to 2



**Minimum environmental
impact, maximum
productivity.**

from 4 to 5

from 6 to 8,5



BIT

 *AC technology*



**BLITZ
3R-4R**

 *AC technology*



**cenTAURO 48
cenTAURO 80**

compact
from 1,6 to 3

 *AC technology*



**BLITZ
250-300-350**

from 2,5 to 3,5

 *AC technology*



**MAK
400-450-500**



ECO-P

Innovation technology

Innovation not as an end in itself, but generated by the demands of an evolving market, and thus oriented towards the creation of value. Innovation across the board, that enables CESAB to be constantly at its customers' side with the state of the art technology.

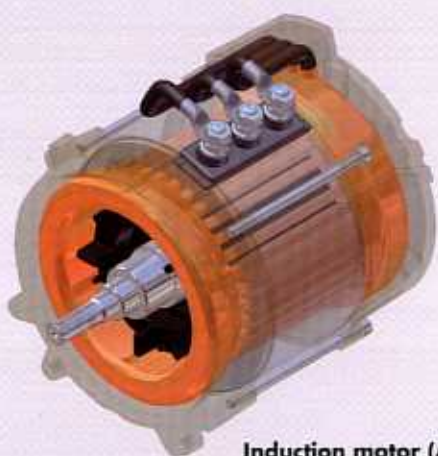

Induction motor (AC)



AC technology,
efficient performance
that raises productivity

All new-generation CESAB trucks are equipped with **induction (AC) electric motors**.

This strategic decision not only improves the trucks' performance in terms of both agility and handling, but also guarantees productivity, safety and **reduced operator fatigue**.

Safe. It is important to be safe.

Precise speed control is an important safety factor, especially during loading. Electronic control of the AC motors guarantees that the truck is stopped by just releasing the accelerator; even on ramps, the truck will descend slowly at controlled speed.



Manoeuvring It has never been so easy

With outstanding traction performance, AC motors are designed to offer greater performance efficiency in all applications: **precise, smooth acceleration, and absolutely predictable truck response**, thanks to the continuous monitoring of the rotation speed and constantly engaged transmission. The capability for **fast, precise combined manoeuvres** both during acceleration and during braking when the accelerator is released.

More effective braking and smoother acceleration than on an equivalent DC model make all manoeuvres quick and safe.

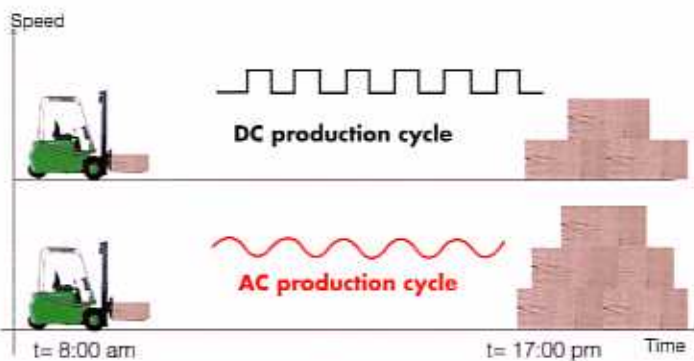

AC Technology allows a smoother acceleration, reduces working cycle time and operator fatigue, increasing productivity.

Programme your driving style.



Easier and more enjoyable to drive, AC Technology trucks become an important factor for increasing the productivity of working cycles. With these machines, the operator has a **flexible** working tool, which can be **further customised** to suit his driving style.

Push-buttons on the steering column allow selection of one of the three driving modes (**HLP**), depending on whether the priority is speed or a customised setting. A special console also allows programming of the **ideal speed and torque combinations**, for both traction and lifting.



The savings from an investment that lasts over time

AC Technology trucks are particularly **competitive** and **beneficial** in terms of both energy consumption and maintenance costs.

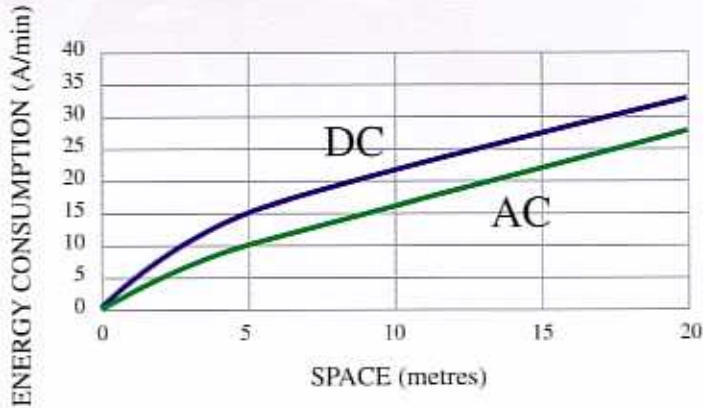

Using the motor as a braking system not only allows energy to be recouped, but also **reduces the use of the mechanical brakes**, thus decreasing their rate of wear. Passive use of the motor by means of **"regenerative braking"** cuts truck down-times and increases productivity, by extending the battery lifetime. Since they have no contactors or other mechanical contacts, AC motors are less subject to wear and as there are no brushes they do not generate running noise, no carbon dust increasing driving comfort and reducing fatigue.

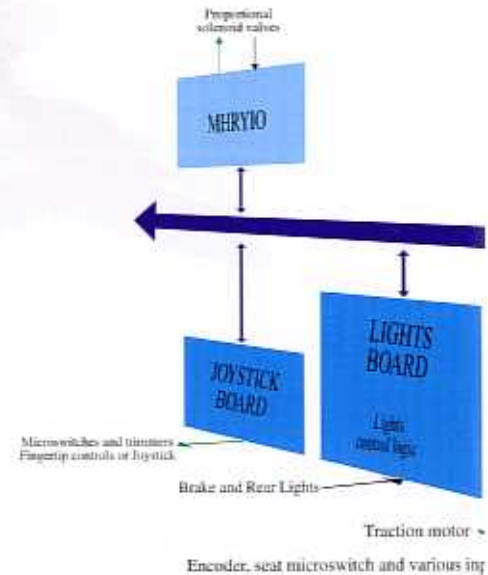

CAN-bus: central control system

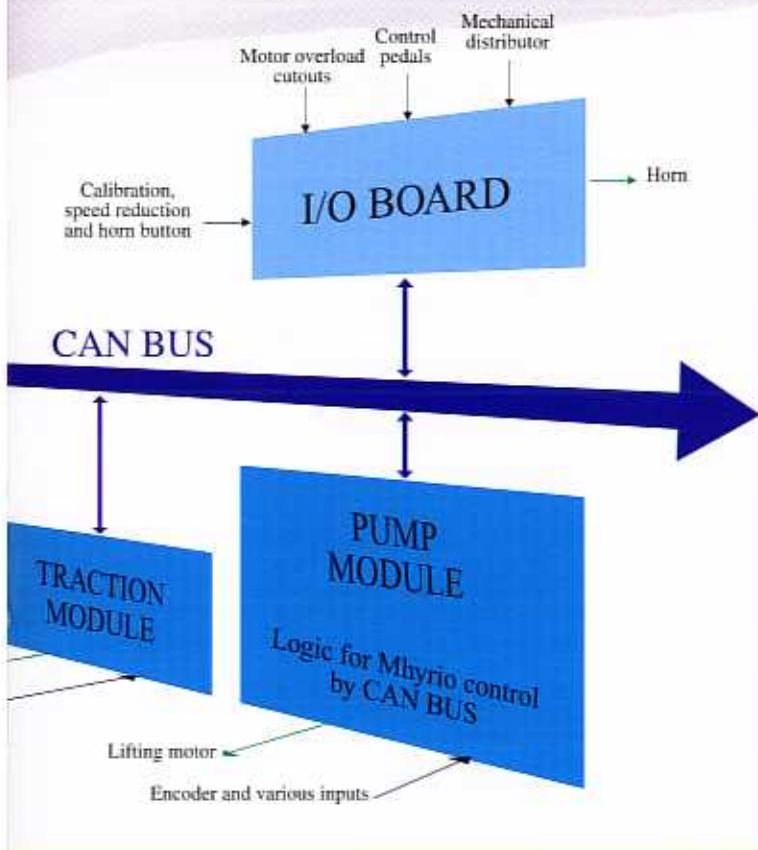

The CAN-BUS makes maintenance even simpler.

The connections between the various components are no longer analogue (with complex wiring), but digital, with a control circuit board (**Central Area Network**) which uses low-voltage components to assure more efficient use of power and improved operator safety. This system is able to receive and process information about the status of all the components, co-ordinating their operation for optimal performance.

There are three main advantages:

1. flexible programming of the control unit;
2. any malfunctions can be traced immediately by means of electronic diagnostics instrumentation;
3. the simpler wiring means improved reliability.

All CESAB electric fork-lift trucks are also available with a multifunction arm-rest with the Mini Joystick or Fingertips controls. These options simplify the operator's job in all handling stages. Direction changes can also be controlled by just pressing the buttons on the arm-rest.



CESAB:

innovations that create
effective, flexible, customised solutions



Available in **3 and 4 wheeled** versions with lifting capacities from **1.2 to 2.0 t**, BLITZ fork-lift trucks offer exceptional **handling, low operating costs** and **driving safety**.

BLITZ trucks are the perfect choice, not only for those in search of a **rapid, agile, precise fork-lift**, but above all for everyone who needs to work in tight spaces in any operating context, from small retail outlets to the automotive and warehouse sectors.

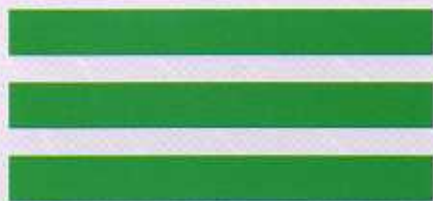

BLITZ **3R-4R**
champions in flexibility

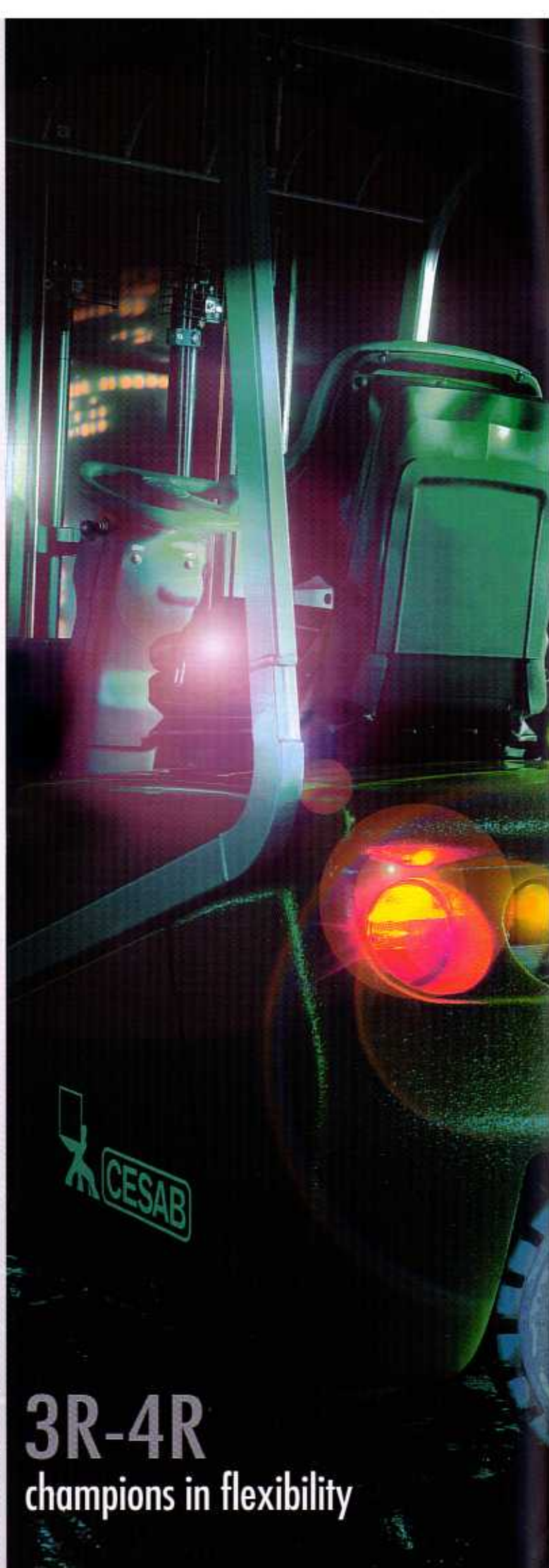

Excellent handling and safety in every situation

The foundation stones of the CESAB range, the three-wheeled BLITZ trucks come with an impressive array of accessories, are **easily manoeuvrable** and, thanks to AC technology, offer **outstanding performance**.

The low centre of gravity assures **excellent stability** and road-holding at any speed, laden or unladen, on the straight and above all when cornering. The **electronic differential** and the **traction precision** of the AC motors offer full control and unrivalled safety on ramps and wet surfaces.

The continuous control of the current delivered to the two front electric motors by continuous monitoring of the steering angle allows the front wheels to counter-turn when cornering.

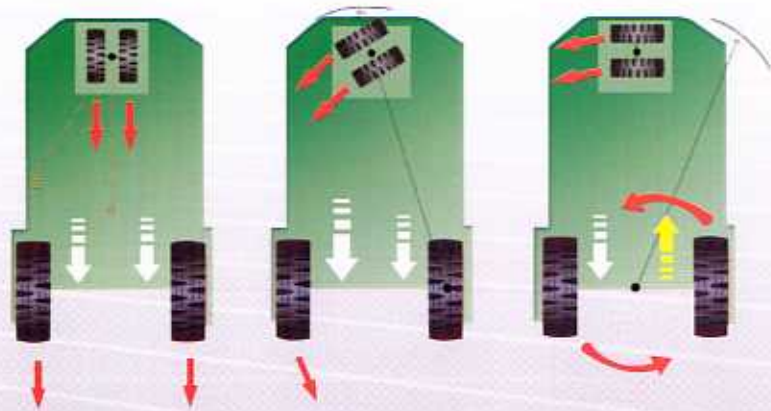

The operator has a choice of **three driving programmes**, as well as an extra speed reduction function.

Small machines, big performance

In BLITZ trucks, traction is assured by **two motors** of 4.5 kW each with **speed reducers located on the front wheels**. The 10 kW lift motor provides power perfectly calibrated to the various types of application.

Thanks to **the electronic differential** controlling the two powerful AC electric motors, which distributes the torque in relation to the steering angle, sharp, hazardous changes in speed are a thing of the past.

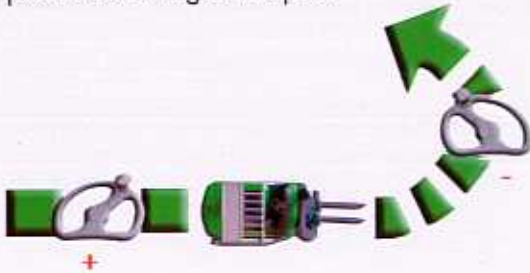

The **electronic control** which **automatically reduces speed on the basis of the steering lock when cornering** increases the safety of the operator and the payload.



Regenerative braking, triggered when the accelerator is released, not only uses the induction motor to recoup kinetic energy and transform it into electricity. It also **allows total control of the truck during all handling stages and on ramps**, with **unrivalled safety for the driver and the load**. What's more, this feature combines with the oil-immersed brakes to **significantly reduce wear and maintenance costs**.



Accessibility from all points

CESAB's proverbial attention to **design** and **ergonomics** is reflected in the simple, elegant styling of all construction details. The **excellent access to the driving seat** makes it easy to get on and off the truck quickly during the working day.



On BLITZ trucks, **all operating parameter adjustments, diagnostic and maintenance procedures are quick and easy.**

The user just connects the Console to the control panel or central ECU before using cascade menus to modify the truck's settings or for rapid diagnostics of systems status.



The rapid changes in the automotive industry and the recent mechanisation of the fruit and vegetable sector have demanded the development of fork-lift trucks able to operate in continuous cycles, combining high lifting capacity with exceptional agility.

CESAB has responded to these needs with the cenTAURO range of compact electric trucks. Extremely **agile** and **compact**, with the many advantages offered by AC technology, they are currently available in the **48 Volt** version with capacities of **1.6** and **2.0 t**, and the **80 Volt** version with capacities of **2.5** and **3.0 t**.



cenTAURO

moving around is child's play

The intelligent axle: the agility of a three-wheeled truck, with performance of a four-wheeled machine

The new concept **steering axle** (with steering angle 97°) and the counter-turning front drive motors enhance the **agility** and **manoeuvrability** of 48 Volt cenTAURO trucks.

The two independent motors, combined with the effect of the electronic differential, allow the truck to achieve **very small turning radiuses** to work in the tightest spaces, with handling comparable to that of a three-wheeled truck. The result is a **compact, stable, agile, fast** truck: a real **handling ace**.

Diagram of 48 Volt cenTAURO steering axle

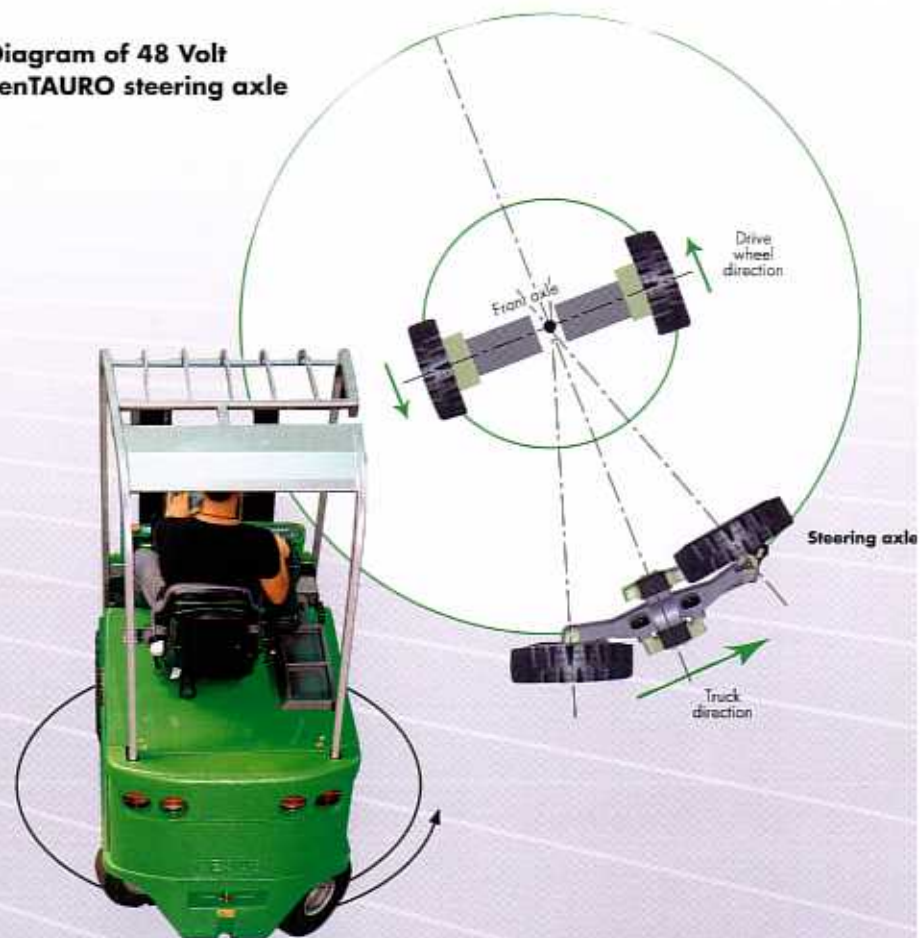

Broaden your horizons

The **exceptional visibility** provided by centTAURO fork-lift trucks is the outcome of the perfect combination of raised driving seat and new-design mast.

The **placing of the lifting cylinders in line with the mast profiles** means they do not interfere with visibility, increasing the operator's safety during all manoeuvres.



The new masts are available in **two and three stage** versions and are therefore particularly effective and safe with bulky loads and multiple pallets. **The masts' high torsional rigidity** allows frequent lifting even to the maximum height.

New Triplex Free Lift Height

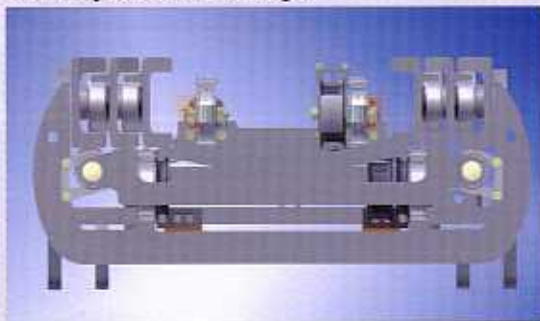

cenTAURO 48-80

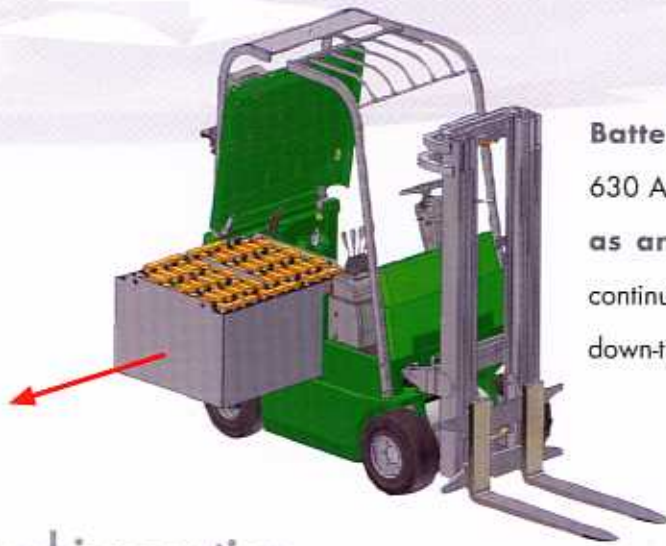

Batteries, with capacities 640 Ah/48 V and 630 Ah/80 V, can be removed to the side as an option, for easy replacement during continuous, multi-shift operations, cutting machine down-times and optimising the truck's productivity.

Comfort and innovation for peak productivity

The **ergonomic driving seat**, the arm-rests with (optional) integrated Mini-Joystick or Fingertips electronic controls, allowing convenient control of all handling functions and the **excellent accessibility** of the driving position, aided by the large, convenient step with non-slip tread, guarantee a **high degree of comfort and greater safety** for the operator.



BLITZ 250 300 350 trucks have the same manoeuvrability as the 4R range, together with greater lifting capacity, from **2.5 to 3.5 t** with **80 Volt** batteries. The **capability for operation on continuous cycles**, combined with the countless advantages of AC technology, make the trucks in this range **particularly suitable for heavy-duty applications** in the steel, cement, timber or beverage industries, achieving performance levels similar to IC trucks.



BLITZ 250-300-350

greater power,
greater productivity



Stability and safety: the ideal combination

On BLITZ trucks, the **excellent stability**, the **perfect handling** and the **total safety** in all types of manoeuvre derive from the **low centre of gravity** and **extra-low battery position**. These features, combined with the generous battery capacity, make this truck the **ideal tool for continuous-cycle operation**, especially in outdoor yards.

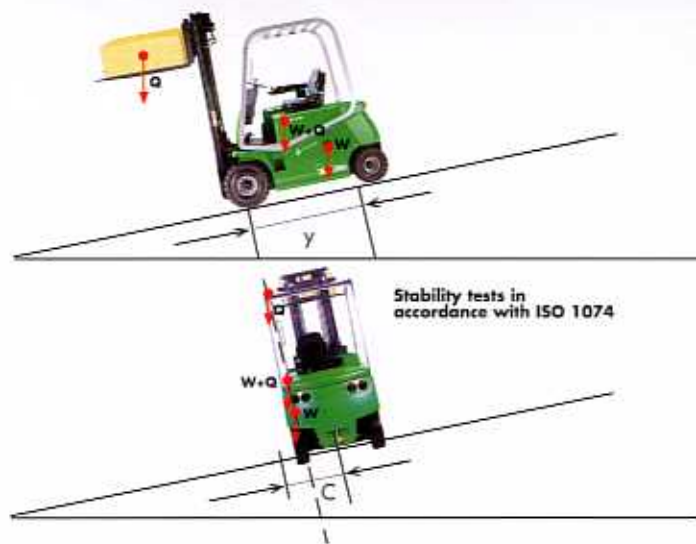

On BLITZ 250 300 350 series trucks, research into stability has led to the design of a vehicle with construction features (own centre of gravity, wheelbase and track) that allow a stable attitude to be maintained in all circumstances.

In the **BLITZ 250 300 350** range, the compact front axle comprises the AC traction motor, the speed reducer, the differential and the oil-immersed brakes. Thanks to their **compact size**, these trucks are **agile in tight spaces**, while traction power up to 14 kW ensures **speed and responsiveness during travel**.

All lifting and handling operations are quick and safe, features guaranteed by outstanding visibility and the characteristic torsional rigidity of the masts.



MAK series fork-lift trucks offer the agility and easy handling typical of AC Technology, combined with an amazing lift capacity of **4 to 5 t**, **adapting to a vast range of applications**: from paper to the ceramics industry and from beverages to steel-works.



MAK

400-450-500

big in performance



CESAB





Unlimited power

MAK trucks are specifically designed for **heavy-duty applications**. All the components are **rugged, powerful and reliable**, guaranteeing greater productivity and the utmost safety. The traction motor of 17kW/80V integrated in the front axle and one 18 kW/80V lift motor assure excellent performance, even with high payloads. What's more, **MAK** trucks are equipped with an **electronic control** system, allowing them to be programmed for any kind of duty, to the operator's specific needs. The **wide selection of** exceptionally durable **large-size tyres available** to order adapt better to the terrain, guaranteeing the truck outstanding **stability and agility**.





Options

All CESAB electric fork-lift trucks can be equipped with a vast range of options to personalise the machine to the customer's operating requirements.

Cabs, panelling and weather protection

Depending on the different application in which CESAB trucks operate, they can be **customised** by choosing from the range of **cabs and panelling packages specially designed by CESAB** for every single model in its electric truck range. Cabs can also be fitted with heating and audio-system.



Tyres

All CESAB electric fork-lift trucks **are equipped with superelastic tyres as standard**. They can be fitted with inflated, cushion or anti-marking tyres on request. Models in the BLITZ 250-300-350 and MAK 400-500 range can also be fitted with twin tyres.



Corrosive environment version

The BLITZ range is available in a **"corrosive environment" version**, ideal for protecting the parts of the trucks most at risk from corrosion.

Lights system

All electric fork-lift trucks can be equipped with **revolving flashing light, working lights and full light system** comprising dipped headlights and direction indicator lights.



Customisation

For special requirements and application, **all CESAB trucks can be supplied with equipment tailored to the needs of specific operations.**



CESAB trucks can be supplied in **alternative colours** to match customers livery.



Drive controls

Available in different versions. Optional foot operated direction control where direction is controlled by forward and reverse accelerator pedals.

